

DCT SE 7,55 HT
Catalytic bead

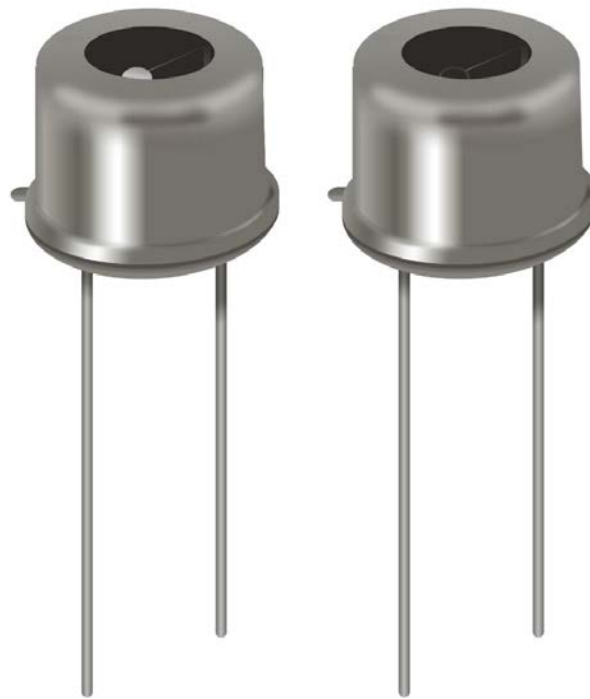

Leading
manufacturer
of instrumentation
since
1997

ERIS DCT SE 7,55 HT catalytic bead **detects a presence and measures concentration of flammable gases and vapours in air in range of 0-100% LEL with overload immunity.** The bead exhibits excellent long term zero and sensitivity stability and a high level of **resistance to catalytic poisons of hydrogen sulphide (H₂S) and hexamethyldisilazane (HMDS).**

Features and Benefits



Investment efficiency and reliability

- Patented material composition of catalytic bead
- Poison resistance
- Overload immunity
- Shock and vibration tolerance
- Detection a vast range of flammable gases including hydrogen (H₂)
- Long term zero and sensitivity stability
- Quality service including an extended warrantee*
- Free 24/7 technical support
- Estimated lifetime is 5 years in clean air

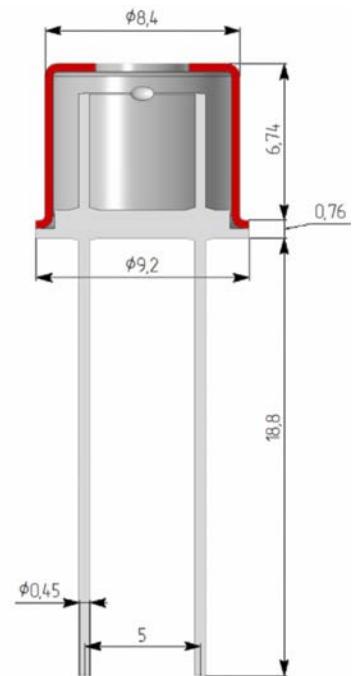

All measurements in mm.

* Additional service for customers

Resistance to H₂S is at least 50000 ppm/ hour

The deviation of the output signal after exposure to 50000 ppm H₂S does not exceed 5%LEL

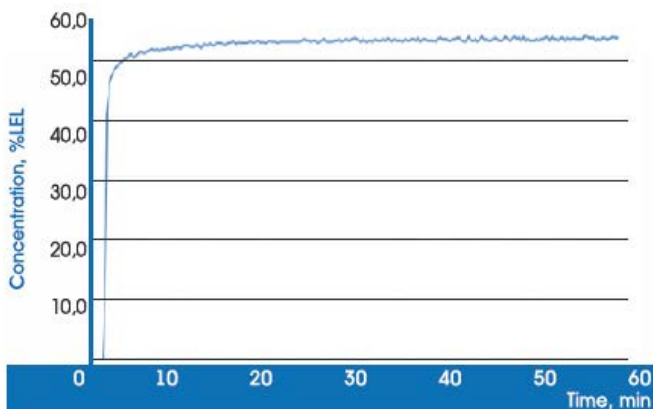

Resistance to HMDS is at least 6000 ppm/ hour

The deviation of the output signal after exposure to 300 ppm HMDS does not exceed 1%LEL

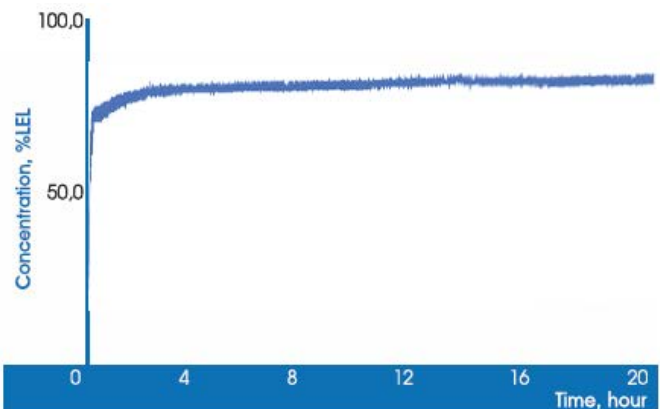

Technical specifications*



Basic data

Diameter	7,55 mm
Bridge Supply Voltage	2,2± 0,1 V
Zero Offset	±20 mV
Sensor Current	280±20 mA
Power Consumption	0,75 W
Range	0-100% LEL
Resolution	1% LEL
Sensitivity (methane)	1±0,2 mV/ LEL
Long Term Zero Drift	< 1% LEL /month
Long Term Sensitivity Drift	< 3% LEL /month
Accuracy	< 5% LEL
Permissible Humidity	0-98% (non-considering)
Pressure	80-120 kPa
T90 Response Time	< 10 seconds
Output Signal	mV
Linearity	0-50% LEL
Temperature Range	-60°C to +155°C
Temperature Drift	< 5% LEL /month

** The performance data in this document are conducted by test environment at 20°C, 50% RH and 1 atm.
Catalytic bead performance varies under different environmental conditions.*

ERIS has a policy of continuous development and improvement of its products.
As such the specification for the device outlined in the data sheet may be changed without notice.

Cross-sensitivity data

№	Gas	Cross Sensitivity Factor (Methan)
1	CH ₄	1.00
2	C ₃ H ₈	0.76
3	C ₄ H ₁₀	0.54
4	C ₅ H ₁₂	0.43
5	H ₂	0.63
6	C ₆ H ₁₄	0.52
7	C ₂ H ₆	0.95
8	C ₂ H ₅ OH	0.46
9	C ₃ H ₆	0.54
10	C ₂ H ₃ Cl	0.77
11	C ₆ H ₁₂	1.08
12	CH ₃ OH	0.80
13	C ₂ H ₄	0.55
14	C ₆ H ₆	0.59
15	C ₂ H ₂	0.79
16	C ₄ H ₆	0.72
17	C ₅ H ₁₂ O	0.73

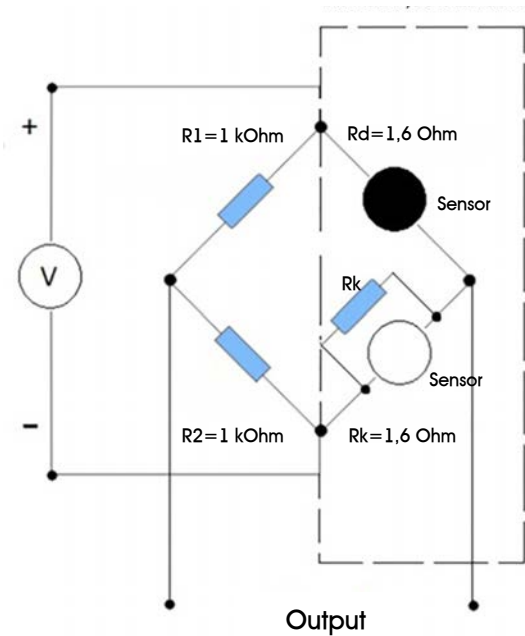

DCT SE 7,55 HT
Recommended circuit diagram

Note: The cross sensitivities include but not limited to the above gases. It may also respond to other gases. The data in the table above may vary from different batches of sensors and the changes of test environment.

Contact details

Address: ERIS KIP LLC, 8/25 Promyshlennaya Str, Tchaikovsky, Perm Region, Russia, 617762

Sales department:
+ 7 34241-6-55-11 add. 170

Sales department Manager:
Sergey Anatolievich Gagara
+ 7-912-987-40-25
E-mail: info@eriskip.ru

Technical support department:
service@eriskip.ru



Over 20 years of experience



www.eriskip.com

Corporate video

